

Derby Diocesan Association of Church Bellringers Consultant's Report	Report no. DDACB 01/003
Inspection of Bell Installation at St. Lawrence, Walton on Trent	Issue date: 11/01/003

1.0 Introduction

This inspection was requested by Mr N Adams, Churchwarden.

To date volunteers from the Derby Diocesan Association of Church Bellringers have carried out a considerable amount of work in the tower to make the bell chamber bird and weather proof. Large quantities of debris have been removed from both the bell chamber and the ringing room. Also new electric lighting has been installed in the clock room and bell chamber.

2.0 Tower (see figure 1)

The tower is located at the west end of the church, it has diagonal buttresses and contains three bells hung for full circle ringing in a wooden frame.

There is a spiral staircase set in the south west corner. Although the treads are in good condition, the stairs are very steep and of uneven rise and so do not provide easy or safe access up and down the tower. They are lit as far as the ringing room by electric lights, but these should now be extended right up to the bell chamber.

There are iron strengthening tie bars set into the wall at intervals up the stairwell and there is a wrought iron tie bar in the ringing room connecting the east and west walls.

The tower roof appears to have been repaired recently and short brick piers set on top of the tower walls provide additional support for the wall plates.

3.0 Ground Floor (see figure 2)

The ground floor of the tower forms the baptistery having a carved wooden screen separating it from the nave. The elegantly carved font cover is counter balanced by a weight in the ringing room above, the two attached to each other via a cable and pulley system.

There is a darkening in colour of the stone walls above a height of about 3.75 metres and evidence of a blocked doorway from the spiral staircase indicating the existence at one time of a gallery. There is a very attractive west window and the ground floor walls are liberally endowed with memorial tablets.

The ceiling (set at a height of 6.5 metres above the ground floor) is fully boarded and so the size and position of any trap door is masked.

4.0 Ringing Room (see figure 3)

The ringing room is reached by 27 steps up the spiral stairway.

The floor appears to have been rebuilt at a lower level at some time. The new entrance has been formed by a considerable excavation of the stonework some 2 metres below the threshold of the original doorway forming a very tall opening and making the adjacent section of spiral stairway even more precarious for users. The original floor level can be judged by the position of its supporting corbels running around each of the walls at a height above the existing floor of 2.0 metres.

There appears to be a trap door in the floor but its dimensions are unknown because the floor is covered by carpet and debris which has yet to be cleared away.

There is a blocked window opening at the current floor level in the west wall which, on the outside of the tower, forms a niche containing a statue of St Lawrence. A further blocked opening in the east wall once communicated with the nave. The counterbalance system for the font cover is set on the east wall.

There is a small window (protected by a metal grill) set 1.4 metres above the corbels in the south wall providing a degree of natural light and ventilation.

The tower is strengthened by a wrought iron tie rod set along the south wall and tying the east and west walls.

The three bell ropes fall in a good circle.

The ceiling is set at a height of 5.53 metres which is safe in event of a ringer being carried upwards following breakage of a stay. The ceiling / clock room floor appears to be very old and is supported by three principle beams and a fourth lesser beam. These beams and associated wall plates rest on corbels set in all four walls.

5.0 Clock Room (see figure 4)

The clock room is reached by a further 19 steps. Due to the angular position of the spiral staircase, entry is through a short passage in the south wall. The room is clean and well lit by electric lighting.

There is a 1.21 X 1.2 metre trap door in the floor of sufficient size to allow the bells to be removed.

The clock drives dials on the south and east sides of the tower and has recently been fitted with an autowind system and strikes the hour on the tenor bell. It is housed in a wooden case with glazed doors and the pendulum swings in a case protruding through the trap opening into the ringing room below.

Set at a height of 2.05 metres, the ceiling comprises two groups of 5 substantial (0.26 X 0.2 metre) beams set across the width of the room and resting on corbels in the north and south walls with a further 4 beams in the centre truncated by a 1.0 X 1.0 metre trap opening to the bell chamber. This opening is sufficiently large to allow the tenor bell to be removed.

6.0 Bell Chamber (see figure 5)

The bell chamber is reached by a further 13 steps. Entry is a tight squeeze between the wall and the bell frame.

There are four louvre openings, three of which are protected by Galebreaker material installed by the Derby Diocesan Association of Church Bellringers. Work continues to protect the fourth opening. The wooden louvres are in excellent condition.

The whole area is clean and free from birds and there is excellent artificial lighting. The roof appears to be in good condition.

7.0 Bells Installation

7.1 Bells

There are three bells hung on ball bearings for full circle ringing, all swinging in a north south direction. Details (taken from "The Church Bells of Derbyshire" by Pat Halls and George Dawson) are in the following table.

Bell No.	Diameter (ins)	Weight (cwts)	Date	Founder
1	33.75	?	1632	William Clibury of Wellington, Shropshire
*2	35.5	?	from 1380	Unknown
3	38.625	8-2-16	1866	John Taylor

The bells have been rehung at some time by the Whitechapel Bellfoundry and the tenor has in turn been rehung again later by Gillett and Johnston. All appear to be crack - free.

The treble and second bells retain their canons (the cast - in loops on top of the bells) and have been quarter turned (rotated 90 degrees about their vertical axes to present unworn faces to the clappers).

*Note – bell 2 is listed on the Diocese of Derby schedule for preservation. For this reason it is unlikely that English Heritage will permit retuning and they will not permit removal of the canons. It is possible that similar restrictions could be applied to bell 1 since this is also of great age.

7.2 Frame (see figure 6)

The bells hang in an old wooden frame (Pickford type 6.B dating from medieval times or later) which is listed on the Diocese of Derby schedule for preservation. This means that any attempt to significantly alter (or scrap) the frame will be strongly resisted by English Heritage.

Some of the old timbers in the frame show strong evidence of their age through loss of material due to rot. The resulting structural weakening has been offset by the addition of both wooden and steel stiffening members within the frame, complemented by the installation of two steel "I" section joists under the foundation beams in the clock room below. These modifications appear to have been effective since when frame movement (relative to the north wall) was measured during this inspection, the following very small displacements were recorded using a dial gauge:

Bell 1 rung full circle	frame movement +/- 0.25 mm
Bell 2 rung full circle	frame movement +/- 0.25 mm
Bell 3 rung full circle	frame movement +/- 0.40 mm

It is worth recording that these measurements were made during a very damp spell of weather which would cause the wood to swell and so tighten the joints. It might be worth rechecking the frame during a long spell of warm and dry weather.

Tower movement was also assessed using a plumb line and found to be small (approx. +/- 1 mm).

7.3 Main Wheels.

They are in fair condition and adequately attached to the headstocks. The wheel on bell 3 shows signs of delamination in the plywood rim.

7.4 Headstocks.

All of the headstocks are made from wood and the headstock for bell 3 has been attacked by woodworm.

Bells 1 and 2 have plate gudgeons held to the headstocks by U bolts which are rusty but sound.

The steel bolts /straps holding the bells to the headstocks are corroded and require derusting and painting.

7.5 Main Bearings.

They are all an old pattern of ball bearing. Bell 3 is difficult to ring over the top 180 degrees of rotation and this may be due to problems with the bearings or vertical movement in the frame. Further investigation is needed.

7.6 Clappers.

Bells 1 and 2 have modern spheroidal graphite cast iron clappers carried on independent crown staples. Bell 3 retains its wrought iron clapper but is also mounted on an independent crown staple. The clapper pivot bearings all show moderate wear and the crown staples for bells 1 and 3 are loose in their headstocks and should be tightened.

7.7 Stays and sliders.

All three of the stays, and also the sliders on bells 1 and 2, are in good condition.

However the slider on bell 3 is unsafe having been made from thin, bent mild steel sheet. It has little torsional stiffness and should be replaced by a properly designed slider.

The clock hammer pull rod has been installed too high under bell 3 and is fouled by the stay during ringing. The rod system should be lowered to avoid damage.

7.8 Ground Pulleys.

All pulleys run on plain bearings and appear to be in good condition. The bearings are a little stiff and should be lubricated with grease. The good condition indicates that the bells have not been rung a great deal since the pulleys were installed many years ago.

8.0 Recommendations

8.1 Extend the stairway lighting up to the bell chamber.

8.2 Clear the remainder of the debris from the ringing room – this is in hand by the volunteer team.

8.3 Remove the rust from all bell fittings using a wire brush – apply primer, undercoat and top coat to prevent further rusting.

Note – it is advisable to remove and then replace each nut in turn to enable a check on the thread condition and application of oil.

8.4 Investigate the cause of difficult ringing for bell 3 – this is in hand by the volunteer team.

8.5 Tighten the independent clappers on bells 1 and 3 – lubricate the threads first and fit new split pins.

8.6 Fit a new slider to bell 3.

8.7 Lower the clock hammer operating rods beneath bell 3 to be clear of the stay.

8.8 Grease the ground pulley bearings.

8.9 Recheck frame movement in the summer.

8.10 Consider replacement of the wooden frame by a steel 6 bell frame which will carry the existing three bells plus three additional bells.

9.0 Conclusions

Assuming recommendations 8.1 to 8.9 are carried out, the existing bells are safe to ring. Access to the ringing room, however, is somewhat hazardous due to the steepness of the stairs. This will deter many potential new ringers.

The wooden frame is very old and its once considerable reserves of strength have been eroded by rotting away of parts of the timbers. This has been offset, over time, by the introduction of additional wooden bracing and steel reinforcements which collectively maintain the stiffness of the frame at a safe level. It is difficult to say how much longer this will continue to be the case and for this reason if ringing is reintroduced the frame condition should be regularly monitored.

An alternative approach would be to install a new steel frame with space for 6 bells and to ring from the ground floor. The old wooden frame would have to be preserved, probably high in the existing ringing room. The Derby Diocesan Association of Bellringers would be pleased to carry out a feasibility study (free of charge) if invited to do so. (This study will not in any way remove the ultimate need for the services of the Church Architect or professional bell hangers).

Please note that this advice has been given in good faith, but no liability is accepted.

Report written by

Mike Banks, Bell Consultant to the DDA

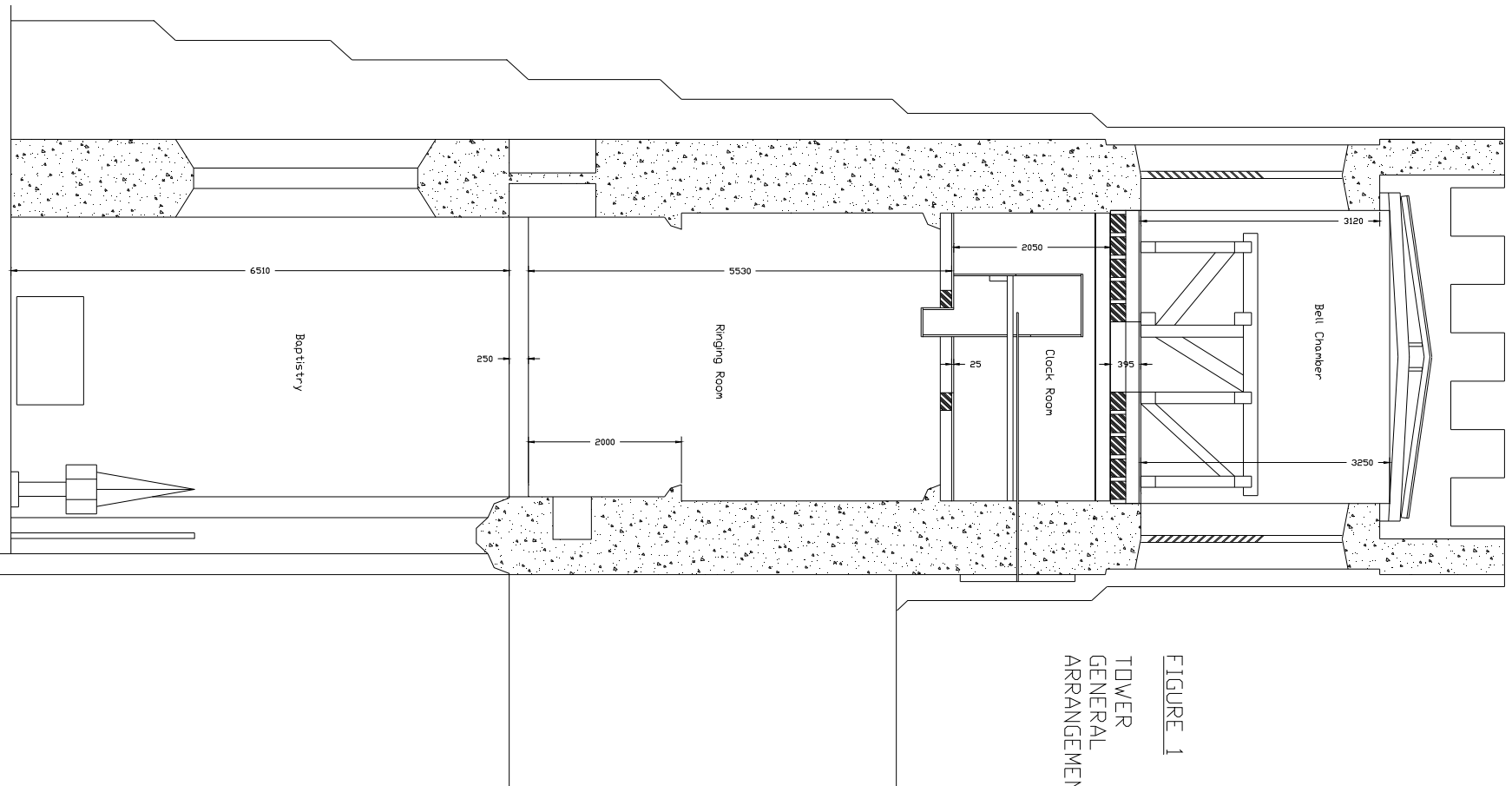

FIGURE 1
 TOWER
 GENERAL
 ARRANGEMENT

FIGURE 2
GROUND FLOOR
BAPTISTRY

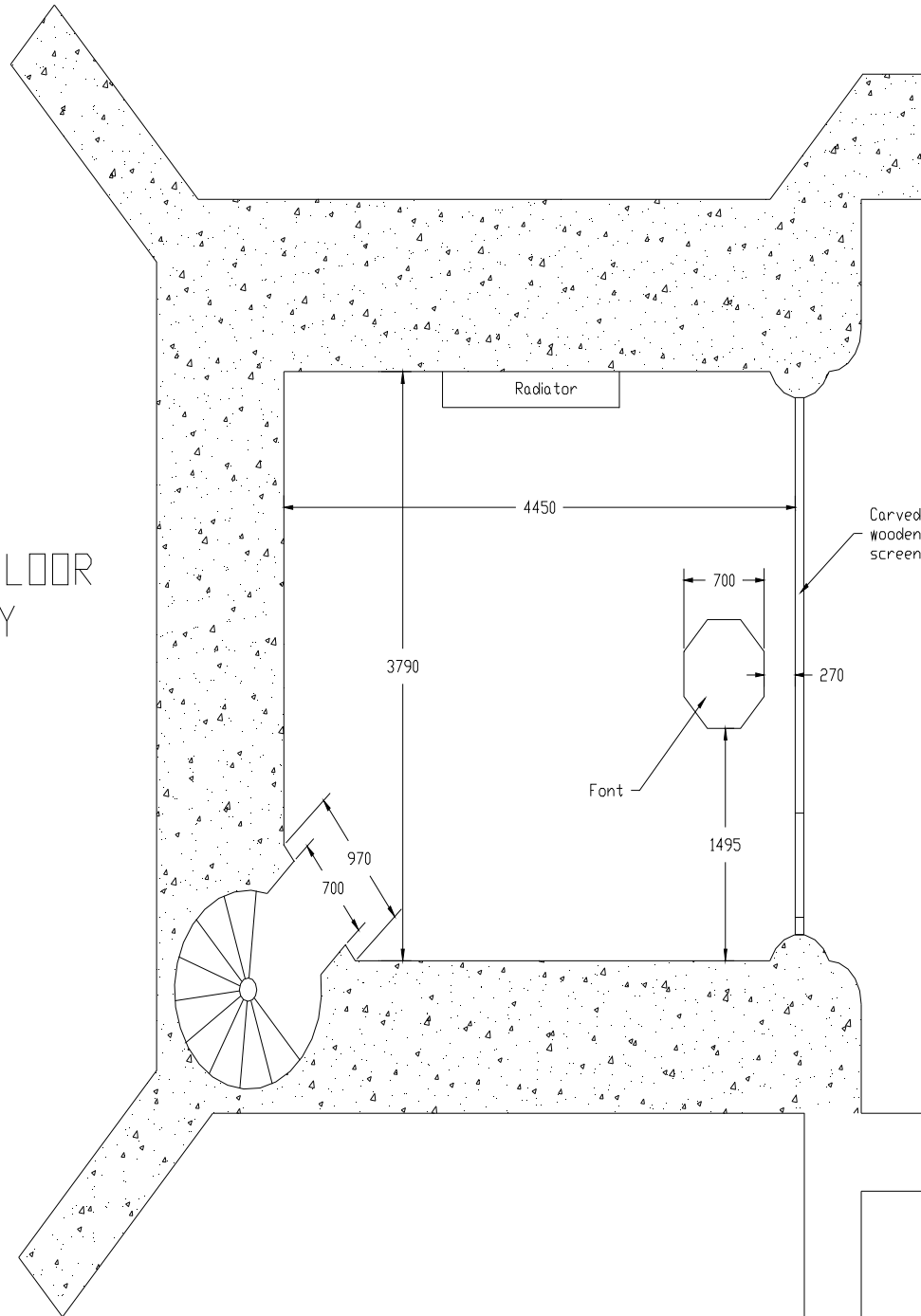

FIGURE 3

RINGING ROOM

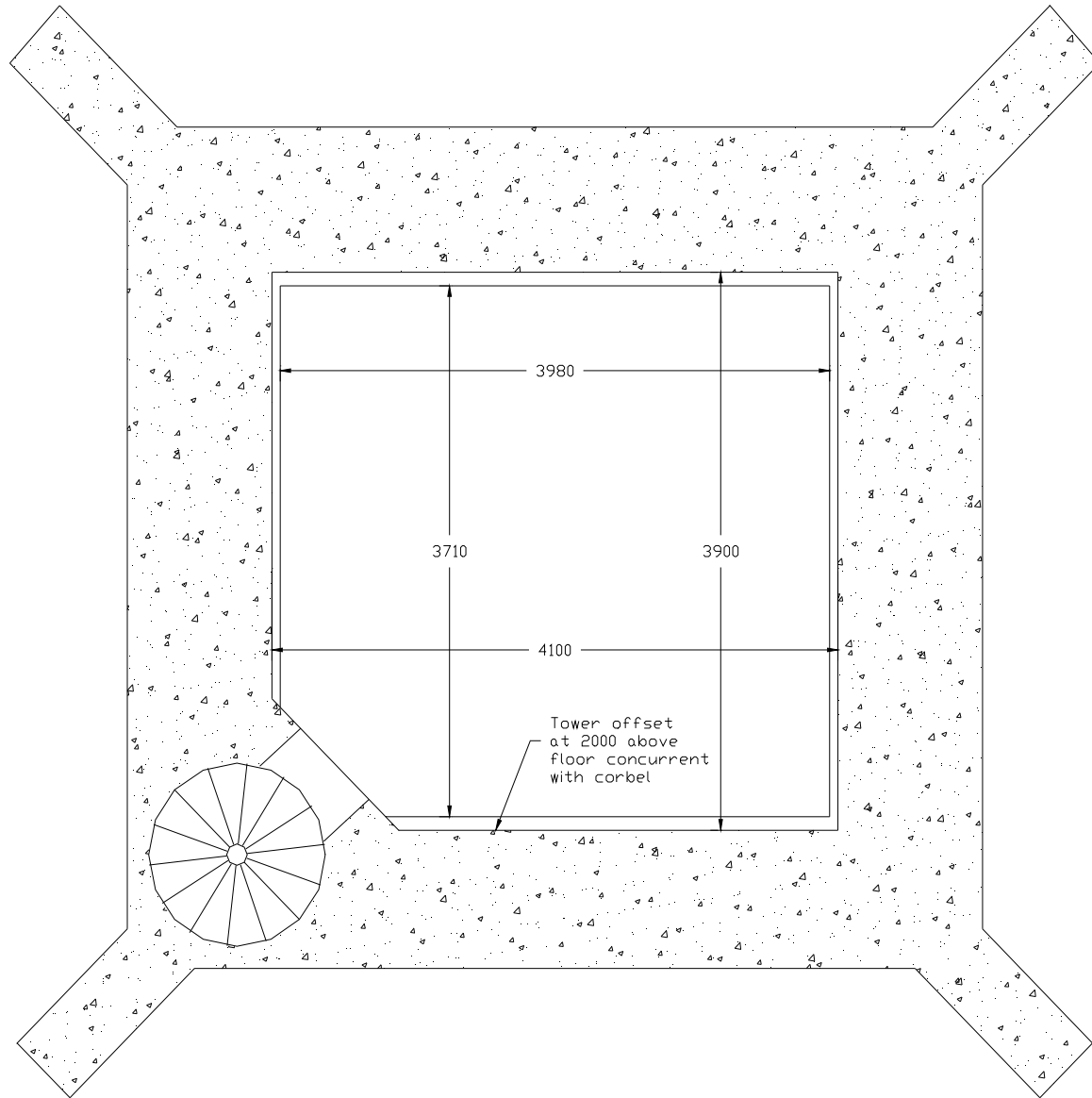

FIGURE 4

CLOCK ROOM

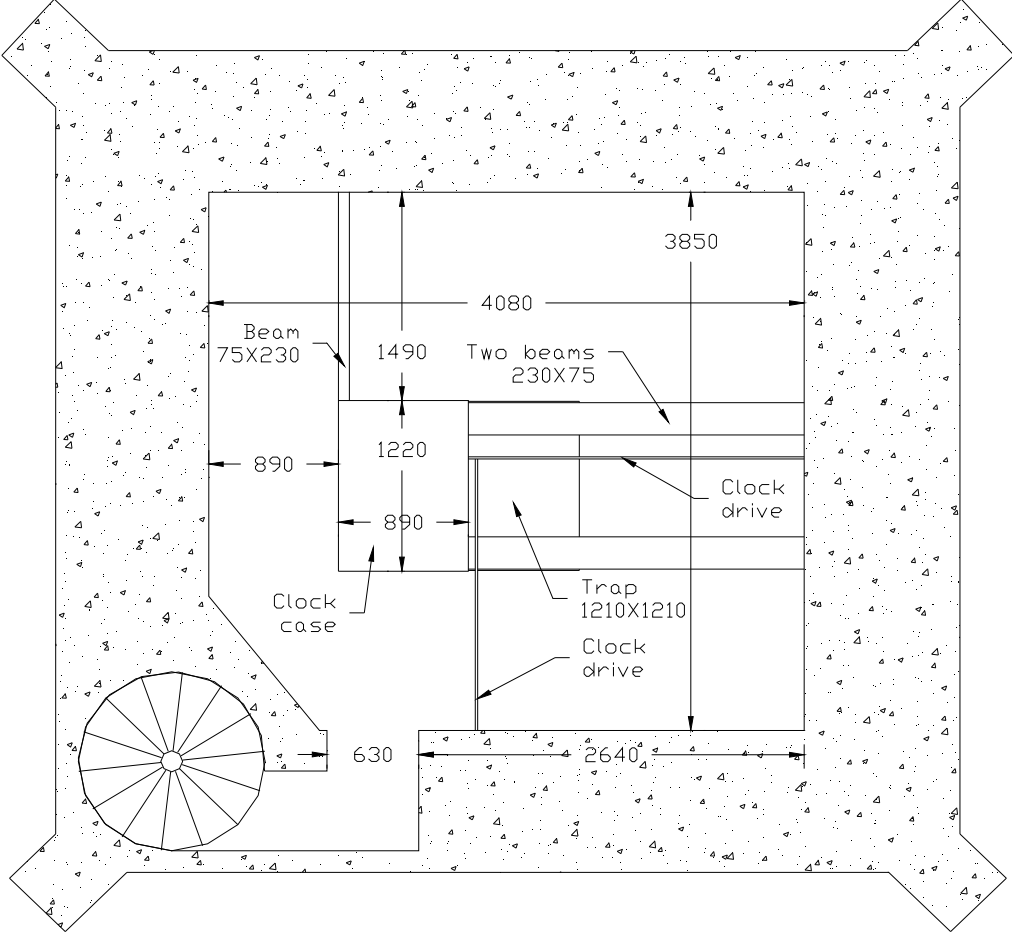
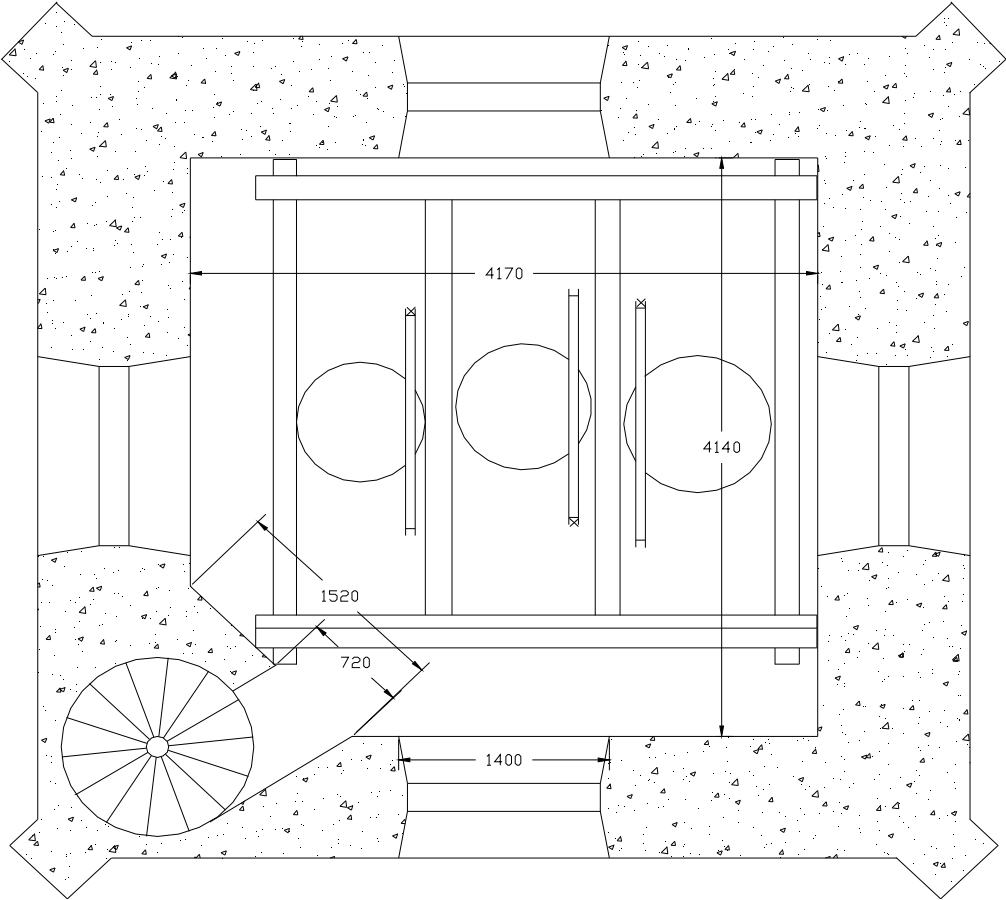

FIGURE 5

BELL CHAMBER



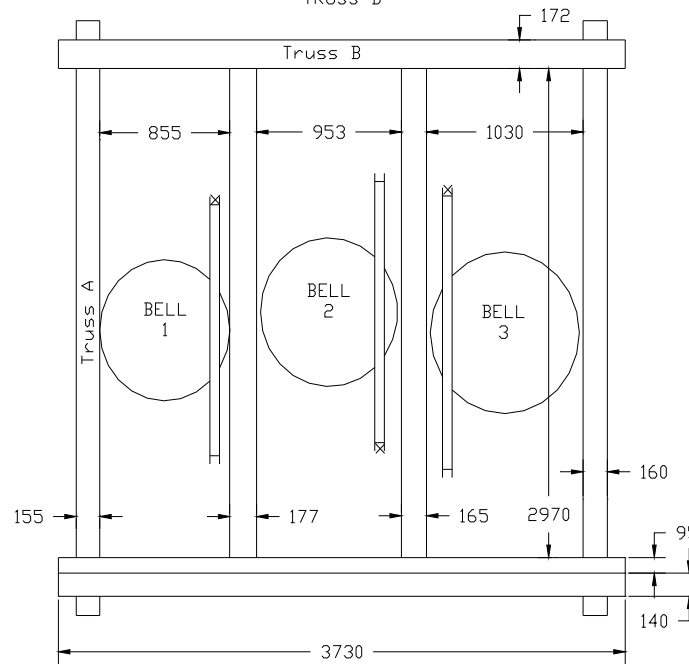
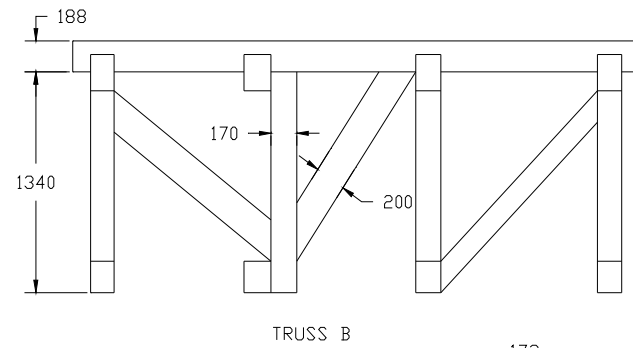
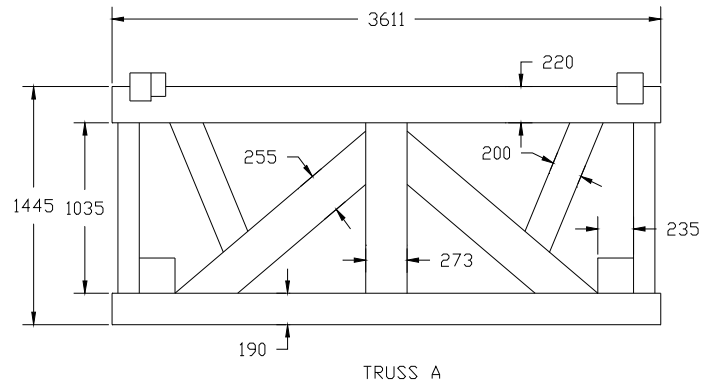

FIGURE 6

GENERAL ARRANGEMENT
OF WOODEN BELL FRAME